



ETA-Danmark A/S
Göteborg Plads 1
DK-2150 Nordhavn
Tel. +45 72 24 59 00
Internet www.etadanmark.dk

Authorised and notified according
to Article 29 of the Regulation (EU)
No 305/2011 of the European
Parliament and of the Council of 9
March 2011

MEMBER OF EOTA



European Technical Assessment ETA-22/0126 of 2022/03/31

General Part

Technical Assessment Body issuing the ETA and designated according to Article 29 of the Regulation (EU) No 305/2011: ETA-Danmark A/S

Trade name of the
construction product:

JT, JF and JZ Screws

Product family to which the
above construction product
belongs:

Fastening screws for metal members and sheeting

Manufacturer:

EJOT Baubefestigungen GmbH
In der Stockwiese 35
DE-57334 Bad Laasphe
Telephone: +49 2752 9080
www.ejot.de

Manufacturing plant:

EJOT Manufacturing Plants 2,8,12,13,15-18,31

This European Technical
Assessment contains:

14 pages including 9 annexes which form an integral
part of the document

This European Technical
Assessment is issued in
accordance with Regulation
(EU) No 305/2011, on the
basis of:

EAD 330046-01-0602 – Fastening screws for metal
members and sheeting

This version replaces:

-

Translations of this European Technical Assessment in other languages shall fully correspond to the original issued document and should be identified as such.

Communication of this European Technical Assessment, including transmission by electronic means, shall be in full (excepted the confidential Annex(es) referred to above). However, partial reproduction may be made, with the written consent of the issuing Technical Assessment Body. Any partial reproduction has to be identified as such.

II SPECIFIC PART OF THE EUROPEAN TECHNICAL ASSESSMENT

1 Technical description of product

The EJOT fastening screws are self-drilling and self-tapping screws listed in Table 1. The fastening screws are made of case hardened carbon steel or stainless steel. They are partly completed with metallic washers and EPDM sealing rings.

The components identified in Table 1 have the geometrical characteristics defined in the Annexes and are factory produced by different manufacturing plants.

Fastening screw	Annex
JT3-ST-2-6,0xL	3
JT4-ST-2-6,0xL	3
JT6-ST-2-6,0xL	3
JT9-ST-2-6,0xL	3
JF3-2-5,5xL E11	4
JF6-2-5,5xL E11	4
JF3-2-6,0xL E11	5
JF3-2-6,0xL E11	5
JT3-2H-Plus-5,5xL E11	6
JT6-2H-Plus-5,5xL E11	6
JT3-6-5,5xL E11	7
JT6-6-5,5xL E11	7
JZ1-6,3xL E11	8
JZ3-6,3xL E11	8
JZ5-6,3xL E11	8
JZ1-S-6,3xL	9
JZ3-S-6,3xL	9

Table 1: Fastening screws included in this ETA.

2 Specification of the intended use(s) in accordance with the applicable European Assessment Document (hereinafter EAD)

The EJOT fastening screws are intended to be used for fastening metal sheeting to metal supporting substructures. The sheeting can either be used as wall or roof cladding or as load bearing wall and roof element. The intended use comprises fastening screws and connections for indoor and outdoor applications. Fastening screws which are intended to be used in external environments with \geq C2 corrosion according to the standard EN ISO 12944-2 are made of stainless steel. Furthermore the intended use comprises connections with predominantly static loads (e.g., wind loads, dead loads).

The fastening screws for metal members and sheeting are not intended for re-use.

The installation should be carried out according to the ETA holder's specifications, using the specific kit components, manufactured by suppliers of the ETA holder and carried out by appropriately qualified staff with supervision of the technical responsible of the site.

The verification and assessment methods on which this European Technical Assessment is based lead to the assumption of a working life of at least 25 years, that the conditions lay down for the installation, packaging, transport and storage as well as appropriate use, maintenance and repair are met.

The indications given on the working life cannot be interpreted as a guarantee given by the manufacturer but are to be regarded only as a means for choosing the right product in relation to the expected economically reasonable working life of the works.

3 Performance of the product and references to the methods used for its assessment.

Characteristic	Assessment of characteristic
3.1 Mechanical resistance and stability (BWR 1)	
Shear resistance of the connection	See information in annex 3-9
Tension resistance of the connection	See information in annex 3-9
Design resistance in case of combined tension and shear forces (interaction)	See information in annex 3-9
Check of deformation capacity in case of constraining forces due to temperature	See information in annex 3-9
Durability	No performance assessed
3.2 Safety in case of fire (BWR 2)	
Reaction to fire	The EJOT fastening screws are classified as Euroclass A1 in accordance with EN 13501-1 and Commission Delegated Regulation 2016/364 on the basis of EC Decision 96/603/EC (as amended) without the need for further testing.

3.8 Methods of verification

The product is fully covered by EAD EAD 330046-01-0602.

3.9 General aspects related to the fitness for use of the product.

The European Technical Assessment is issued for the product based on agreed data/information, deposited with ETA-Danmark, which identifies the product that has been assessed and judged. Changes to the product or production process, which could result in this deposited data/information being incorrect, should be notified to

ETA-Danmark before the changes are introduced. ETA-Danmark will decide if such changes affect the ETA and consequently the validity of the CE marking based on the ETA and if so whether further assessment or alterations to the ETA, shall be necessary.

The EJOT fastening screws JT, JF and JZ are manufactured in accordance with the provisions of this European Technical Assessment using the manufacturing processes as identified in the inspection of the plant by the notified inspection body and laid down in the technical documentation.

4 Assessment and verification of constancy of performance (hereinafter AVCP) system applied, with reference to its legal base.

4.1 AVCP system

According to the decision 1998/214/ECEC of the European Commission, as amended by 2001/596/EC, the system(s) of assessment and verification of constancy of performance (see Annex III to Regulation (EU) No 305/2011) is 2+.

5 Technical details necessary for the implementation of the AVCP system, as foreseen in the applicable EAD.

Technical details necessary for the implementation of the AVCP system are laid down in the control plan deposited at ETA-Danmark prior to CE marking.

Issued in Copenhagen on 2022-03-28 by

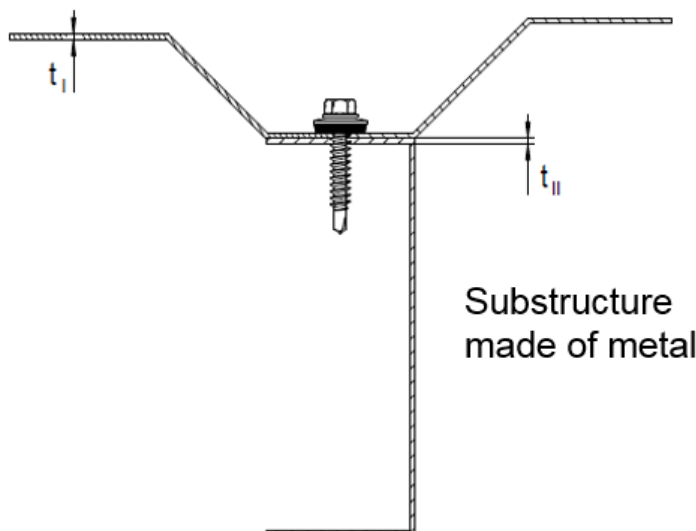

Thomas Bruun
Managing Director, ETA-Danmark

Examples of execution and connection**Materials and dimensions**

Design relevant materials and dimensions are indicated in the Annexes of the fastening screws:

Fastener	Material of the fastening screw
Washer	Material of the sealing washer
Component I	Material of the metal member and sheeting
Component II	Material of the supporting structure

$t_{N,I}$	Thickness of component I
$t_{N,II}$	Thickness of component II made of metal
d_{pd}	Pre-drill diameter of component II
$M_{t,nom}$	Tightening torque of the fastening screw

The thickness $t_{N,II}$ corresponds to the load-bearing screw-in length of the fastening screw in component II, if the load-bearing screw-in length does not cover the entire component thickness.

Component I

The component to be fastened is made of steel or aluminium. It is thicker than the supporting structure ($t_I \geq 3,0$ mm or $t_I \geq 5,0$ mm for screws with countersunk head). Therefore component I is not expected to have the limiting resistance within the connection. This has to be ensured by the user of this ETA. The components are usually pre-punched. The range of the pre-punch diameter can be found on the individual annex of the fastener.

Component II

The fastening is made to metallic supporting structures.

Steel S235 to S275 according to EN 10025-1

S280GD to S450GD according to EN 10346

HX350LAD to HX460LAD according to EN 10346

Aluminium ($R_m \geq 145$ N/mm² to ≥ 245 N/mm²)

Performance characteristics

The design relevant performance characteristics of a connection are indicated in the Annexes of the fastening screws.

$N_{R,k}$	Characteristic value of tension resistance
$V_{R,k}$	Characteristic value of shear resistance

In some cases, component-specific performance characteristics are indicated for an individual calculation in the design relevant performance characteristics of a connection:

$N_{R,I,k}$	Characteristic value of pull-through resistance for component I
$N_{R,II,k}$	Characteristic value of pull-out resistance for component II
$V_{R,I,k}$	Characteristic value of hole bearing resistance for component I
$V_{R,II,k}$	Characteristic value of hole bearing resistance for component II

Terms and explanations

Fastening screws JT, JF and JZ

Annex 1

Occurred loadings of a connection

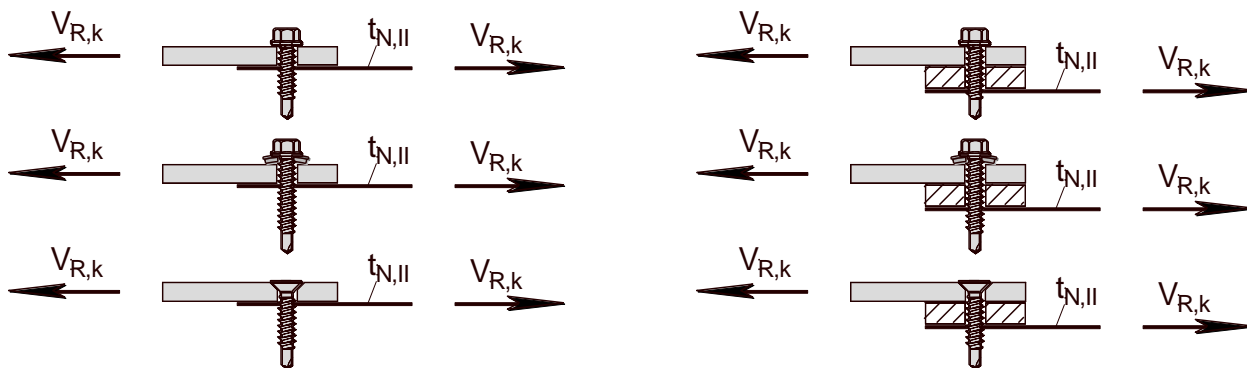

Design values

The design values of tension and shear resistance of a connection have to be determined as following:

- $N_{R,d}$ Design value of tension resistance
- $V_{R,d}$ Design value of shear resistance
- γ_M Partial safety factor

The recommended partial safety factor γ_M is 1,33, provided no partial safety factor is given in national regulations or national Annexes to Eurocode 3.

Special conditions

If the component thickness $t_{N,I}$ or $t_{N,II}$ lies in between two indicated component thicknesses, the characteristic value may be calculated by linear interpolation.

For asymmetric components II made of metal (e.g. Z- or C-shaped profiles) with component thickness $t_{N,II} < 3$ mm, the characteristic value $N_{R,k}$ has to be reduced to 70%.

In case of combined loading by tension and shear forces the following interaction, equation has to be taken into account:

$$\frac{N_{S,d}}{N_{R,d}} + \frac{V_{S,d}}{V_{R,d}} \leq 1,0$$

- $N_{S,d}$ Design value of the applied tension forces
- $V_{S,d}$ Design value of the applied shear forces

Installation conditions

- The installation is carried out according to manufacturer`s instruction.
- The load-bearing screw-in length of the fastening screw specified by the manufacturer has to be taken into account.
- The fastening screws have to be processed with suitable drill driver (e.g., cordless drill driver with depth control). The use of impact wrench is not allowed.
- The fastening screws have to be fixed rectangular to the surface of the component.
- Component I and component II have to be in direct contact to each other. The use of compression resistant thermal insulation strips up to a thickness of 3 mm is allowed.

Design, Installation and additional provisions

Fastening screws JT, JF and JZ

Annex 2

Material:

Screw: JT3 stainless steel (A2) - EN ISO 3506
 JT4 stainless steel (A2) - EN ISO 3506
 JT6 stainless steel (A4) - EN ISO 3506
 JT9 stainless steel (A4) - EN ISO 3506

Washer: none

Component I: Aluminium alloy or steel, thicker than the supporting structure $t_i \geq 5,0$ mm usually pre-punched from 6,0 mm to 8,5 mm.

Component II: S235 according to EN 10025-1
 S280GD to S350GD according to EN 10346 (Table 1.1 and 1.2)
 Aluminium alloy according to EN 573 (Table 1.3)

Table 1.1: Single-layer supporting structure made of S235 or S280GD to S350GD

$t_{N,II}$ [mm]	0,40	0,50	0,55	0,60	0,63	0,70	0,75	0,88	1,00	1,13	1,25	1,50
S280GD	$N_{R,k,II}^{1,2}$ [kN]	0,53	0,75	0,77	0,79	0,80	0,95	1,05	1,35	1,63	1,96	3,02
	$V_{R,k,II}^2$ [kN]	0,61	0,91	1,01	1,12	1,17	1,46	1,67	2,01	2,32	2,84	4,59

¹ For $t_{N,II}$ from S320GD or S350GD, the values may be increased by 8.3%.

² Steel applications only for JT3-S-2-6,0xL and JT6-S-2-6,0xL.

Table 1.2: Two-layer supporting structure made of S235 or S280GD to S350GD

$t_{N,II}$ [mm]	2 x 0,63	2 x 0,70	2 x 0,75	2 x 0,88	2 x 1,00	
S280GD	$N_{R,k,II}^{1,2}$ [kN]	0,80	0,95	2,09	2,91	3,73
	$V_{R,k,II}^2$ [kN]	1,17	1,46	1,67	2,01	2,32

¹ For $t_{N,II}$ from S320GD or S350GD, the values may be increased by 8.3%.

² Steel applications only for JT3-S-2-6,0xL and JT6-S-2-6,0xL.

Table 1.3: Single-layer aluminum alloy supporting structure according to EN 573

$t_{N,II}$ [mm]	0,40	0,50	0,60	0,70	0,80	0,90	1,00	1,10	1,20	1,50	2,00	
$R_m \geq 165$ N/mm ²	$N_{R,k,II}^1$ [kN]	0,22	0,28	0,35	0,43	0,50	0,58	0,68	0,77	0,86	1,18	1,81
	$V_{R,k,II}^1$ [kN]	-	-	-	-	0,71	0,98	1,24	1,51	1,78	2,59	3,93
$R_m \geq 215$ N/mm ²	$N_{R,k,II}^1$ [kN]	0,29	0,37	0,46	0,55	0,64	0,75	0,87	1,00	1,12	1,53	2,33
	$V_{R,k,II}^1$ [kN]	-	-	-	-	0,91	1,25	1,59	1,93	2,27	3,29	4,99

¹ For aluminum with tensile strengths between the specified values, interpolation is allowed.

Characteristic capacities of the fastener	Annex 3
JT3-ST-2-6,0xL, JT4-ST-2-6,0xL, JT6-ST-2-6,0xL and JT9-ST-2-6,0xL	

Material:

Screw: JF3 stainless steel (A2) - EN ISO 3506
JF6 stainless steel (A4) - EN ISO 3506
(Head variations FR or LT possible)

Washer: stainless steel (A2/A4) - EN ISO 3506
With vulcanized EPDM seal

Component I: Aluminium alloy or steel, thicker than the supporting structure $t_i \geq 3,0$ mm usually pre-punched from 5,5 mm to 8,0 mm.

Component II: S280GD to S350GD according to EN 10346 (Table 2.1 and 2.2)
Aluminium alloy according to EN 573 (Table 2.3)

Table 2.1: Single-layer supporting structure made of S280GD to S350GD

$t_{N,II}$ [mm]	0,40	0,50	0,55	0,60	0,63	0,70	0,75	0,88	1,00	
S280GD	$N_{R,k,II}^1$ [kN]	0,60	0,82	0,94	1,07	1,14	1,32	1,44	1,80	2,14
	$V_{R,k,II}$ [kN]	0,86	0,97	1,03	1,08	1,13	1,67	2,06	2,17	2,28

¹ For $t_{N,II}$ from S320GD or S350GD, the values may be increased by 8.3%.

Table 2.2: Two-layer supporting structure made of S280GD to S350GD

$t_{N,II}$ [mm]	2 x 0,63	2 x 0,70	2 x 0,75	2 x 0,88	2 x 1,00	
S280GD	$N_{R,k,II}^1$ [kN]	2,11	2,52	2,88	3,52	-
	$V_{R,k,II}$ [kN]	1,13	1,67	2,06	2,17	-

¹ For $t_{N,II}$ from S320GD or S350GD, the values may be increased by 8.3%.

Table 2.3: Single-layer aluminum alloy supporting structure according to EN 573

$t_{N,II}$ [mm]	0,40	0,50	0,60	0,70	0,80	0,90	1,00	1,10	1,20	1,50	2,00	
$R_m \geq 165$ N/mm ²	$N_{R,k,II}^1$ [kN]	0,24	0,35	0,45	0,58	0,69	0,80	0,91	1,02	1,13	1,63	1,63
	$V_{R,k,II}^1$ [kN]	-	0,37	0,68	1,00	1,31	1,62	1,93	2,25	2,56	3,50	5,07
$R_m \geq 215$ N/mm ²	$N_{R,k,II}^1$ [kN]	0,31	0,46	0,60	0,75	0,89	1,04	1,18	1,33	1,47	2,12	2,12
	$V_{R,k,II}^1$ [kN]	-	0,48	0,88	1,28	1,66	2,07	2,47	2,87	3,27	4,46	6,45

¹ For aluminum with tensile strengths between the specified values, interpolation is allowed.

Characteristic capacities of the fastener	Annex 4
JF3-(FR/LT)-2-5,5xL E11 and JF6-(FR/LT)-2-5,5xL E11	

	<p>Material:</p> <p>Screw: JF3 stainless steel (A2) - EN ISO 3506 JF6 stainless steel (A4) - EN ISO 3506 (Head variations FR or LT possible)</p> <p>Washer: stainless steel (A2/A4) - EN ISO 3506 With vulcanized EPDM seal</p> <p>Component I: Aluminium alloy or steel, thicker than the supporting structure $t_i \geq 3,0$ mm usually pre-punched from 6,0 mm to 8,5 mm.</p> <p>Component II: S280GD to S350GD according to EN 10346 (Table 3.1 and 3.2) Aluminium alloy according to EN 573 (Table 3.3)</p>
---	--

Table 3.1: Single-layer supporting structure made of S280GD to S350GD

$t_{N,II}$ [mm]	0,40	0,50	0,55	0,60	0,63	0,70	0,75	0,88	1,00	
S280GD	$N_{R,k,II}$ [kN]	0,59	0,80 ¹	0,97 ¹	1,14 ¹	1,24 ¹	1,47 ¹	1,64 ¹	1,95 ¹	2,23 ¹
	$V_{R,k,II}$ [kN]	0,95	1,16	1,29	1,43	1,57	1,88	2,11	2,30	2,48

¹ For $t_{N,II}$ from S320GD or S350GD, the values may be increased by 8.3%.

Table 3.2: Two-layer supporting structure made of S280GD to S350GD

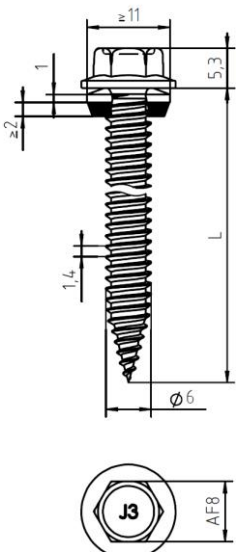
$t_{N,II}$ [mm]	2 x 0,63	2 x 0,70	2 x 0,75	2 x 0,88	2 x 1,00	
S280GD	$N_{R,k,II}$ ¹ [kN]	1,24	1,47	1,64	1,95	-
	$V_{R,k,II}$ [kN]	1,57	1,88	2,11	2,30	-

¹ For $t_{N,II}$ from S320GD or S350GD, the values may be increased by 8.3%.

Table 3.3: Single-layer aluminum alloy supporting structure according to EN 573

$t_{N,II}$ [mm]	0,40	0,50	0,60	0,70	0,80	0,90	1,00	1,10	1,20	1,50	2,00
$R_m \geq 165$ N/mm ²	$N_{R,k,II}$ ¹ [kN]	0,20	0,36	0,50	0,63	0,77	0,82	0,87	1,11	1,35	1,57
	$V_{R,k,II}$ ¹ [kN]	0,32	0,48	0,66	0,83	1,01	1,12	1,23	1,51	1,80	2,65
$R_m \geq 215$ N/mm ²	$N_{R,k,II}$ ¹ [kN]	0,21	0,47	0,65	0,82	1,00	1,07	1,14	1,42	1,70	2,04
	$V_{R,k,II}$ ¹ [kN]	0,35	0,63	0,86	1,09	1,32	1,47	1,61	1,98	2,35	3,45

¹ For aluminum with tensile strengths between the specified values, interpolation is allowed.

Characteristic capacities of the fastener	Annex 5
JF3-(FR/LT)-2-6,0xL E11 and JF6-(FR/LT)-2-6,0xL E11	

Material:

Screw: JT3 stainless steel (A2) - EN ISO 3506
JT6 stainless steel (A4) - EN ISO 3506
(Head variations FR possible)

Washer: stainless steel (A2/A4) - EN ISO 3506
With vulcanized EPDM seal

Component I: Aluminium alloy or steel, thicker than the supporting structure $t_i \geq 3,0$ mm usually pre-punched from 5,5 mm to 8,0 mm.

Component II: S235 to S275 according to EN 10025-1
S280GD to S450GD according to EN 10346
HX350LAD to HX460LAD according to EN 10346 (Table 4.1 and 4.2)
Aluminium alloy according to EN 573 (Table 4.3)

Table 4.1: Single-layer supporting structure made of S235 to S275, S280GD to S450GD or HX350LAD to HX460LAD

$t_{N,II}$ [mm]	0,40	0,50	0,55	0,60	0,63	0,70	0,75	0,88	1,00	1,13	1,25	1,50
S280GD	$N_{R,k,II}$ ¹ [kN]	0,30	0,41	0,47	0,53	0,56	0,66	0,73	1,06	1,40	1,71	2,59
	$V_{R,k,II}$ [kN]	0,59	0,81	0,91	0,93	1,05	1,42	1,69	2,17	2,61	2,98	3,60

¹ For $t_{N,II}$ from S320GD to S450GD respectively HX340LAD to HX460LAD, the values may be increased by 8.3%.

Table 4.2: Two-layer supporting structure made of S235 to S275, S280GD to S450GD or HX350LAD to HX460LAD

$t_{N,II}$ [mm]	2 x 0,63	2 x 0,70	2 x 0,75	2 x 0,88	2 x 1,00	
S280GD	$N_{R,k,II}$ ¹ [kN]	1,01	1,46	1,78	2,31	2,84
	$V_{R,k,II}$ [kN]	2,22	2,83	3,27	3,65	4,00

¹ For $t_{N,II}$ from S320GD to S450GD respectively HX340LAD to HX460LAD, the values may be increased by 8.3%.

Table 4.3: Single-layer aluminum alloy supporting structure according to EN 573

$t_{N,II}$ [mm]	0,40	0,50	0,60	0,70	0,80	0,90	1,00	1,10	1,20	1,50	2,00	
$R_m \geq 165$ N/mm ²	$N_{R,k,II}$ ¹ [kN]	0,14	0,21	0,28	0,36	0,43	0,50	0,56	0,65	0,73	0,91	0,91
	$V_{R,k,II}$ ¹ [kN]	0,15	0,36	0,48	0,59	0,71	0,93	1,14	1,26	1,38	1,73	2,65
$R_m \geq 215$ N/mm ²	$N_{R,k,II}$ ¹ [kN]	0,19	0,28	0,37	0,47	0,56	0,65	0,73	0,84	0,95	1,19	1,19
	$V_{R,k,II}$ ¹ [kN]	0,20	0,47	0,62	0,77	0,92	1,21	1,49	1,64	1,79	2,25	3,45

¹ For aluminum with tensile strengths between the specified values, interpolation is allowed.

Characteristic capacities of the fastener	Annex 6
JT3-(FR)-2H-Plus-5,5xL E11 and JT6-(FR)-2H-Plus-5,5xL E11	

	<p>Material:</p> <p>Screw: JT3 stainless steel (A2) - EN ISO 3506 JT6 stainless steel (A4) - EN ISO 3506 (Head variations FR possible)</p> <p>Washer: stainless steel (A2/A4) - EN ISO 3506 With vulcanized EPDM seal</p> <p>Component I: Aluminium alloy or steel, thicker than the supporting structure $t_i \geq 3,0$ mm usually pre-punched from 5,5 mm to 8,0 mm.</p> <p>Component II: S235 to S355 according to EN 10025-1 S280GD to S350GD according to EN 10346 HX350LAD to HX460LAD according to EN 10346 (Table 5.1) Aluminium alloy according to EN 573 (Table 5.2)</p>
--	--

Table 5.1: Single-layer supporting structure made of S235 to S355, S280GD to S350GD or HX350LAD to HX460LAD

$t_{N,II}$ [mm]		1,50	2,00	2,50	3,00	4,00	5,00	6,00
S280GD	$N_{R,k,II}$ [kN]	1,90	2,60	4,23	5,01	7,04	-	-
	$V_{R,k,II}$ [kN]	2,20	3,33	3,68	4,03	4,73	-	-

Table 5.2: Single-layer aluminum alloy supporting structure according to EN 573

$t_{N,II}$ [mm]		2,00	2,50	3,00	4,00	5,00	6,00
$R_m \geq 165$ N/mm ²	$N_{R,k,II}^1$ [kN]	1,03	1,68	2,33	2,63	2,63	-
	$V_{R,k,II}^1$ [kN]	2,56	2,83	3,10	3,63	3,63	-
$R_m \geq 215$ N/mm ²	$N_{R,k,II}^1$ [kN]	1,35	2,20	3,04	4,73	4,73	-
	$V_{R,k,II}^1$ [kN]	3,33	3,68	4,03	4,73	4,73	-

¹ For aluminum with tensile strengths between the specified values, interpolation is allowed.

Characteristic capacities of the fastener	Annex 7
JT3-(FR)-6-5,5xL E11 and JT6-(FR)-6-5,5xL E11	

Material:

Screw: JZ1 stainless steel (A8) - EN ISO 3506
 JZ3 stainless steel (A2) - EN ISO 3506
 JZ5 stainless steel (A2) - EN ISO 3506

Washer: stainless steel (A2/A4) - EN ISO 3506
 With vulcanized EPDM seal

Component I: Aluminium alloy or steel, thicker than the supporting structure $t_i \geq 3,0$ mm usually pre-punched from 6,3 mm to 8,5 mm.

Component II: S235 to S355 according to EN 10025-1
 S280GD to S450GD according to EN 10346
 HX350LAD to HX460LAD according to EN 10346 (Table 6.1)
 Aluminium alloy according to EN 573 (Table 6.2)

Table 6.1: Single-layer supporting structure made of S235 to S355, S280GD to S450GD or HX350LAD to HX460LAD

$t_{N,II}$ [mm]	1,25	1,50	2,00	3,00	4,00	5,00	6,00	
d_{pd} [mm]	\varnothing 5,0		\varnothing 5,3				\varnothing 5,5	
S280GD	$N_{R,k,II}^1$ [kN]	2,00	2,70	3,60	6,00	8,80	11,60	13,40
	$V_{R,k,II}^1$ [kN]	5,11	5,43	6,06	6,40	6,74	7,08	7,42

¹ S275 to S355, S390GD to S450GD and HX340LAD to HX460LAD only for JZ5-6,3xL.

Table 6.2: Single-layer aluminum alloy supporting structure according to EN 573

$t_{N,II}$ [mm]	1,20	1,50	2,00	2,50	3,00	4,00	5,00	6,00	7,00	
d_{pd} [mm]	\varnothing 4,5				\varnothing 5,0	\varnothing 5,3		\varnothing 5,5		
$R_m \geq 165$ N/mm ²	$N_{R,k,II}^1$ [kN]	0,54	0,77	1,23	1,77	2,38	3,68	5,30	7,06	7,06
	$V_{R,k,II}^1$ [kN]	0,87	2,15	2,30	2,53	2,69	3,07	3,16	3,24	3,33
$R_m \geq 215$ N/mm ²	$N_{R,k,II}^1$ [kN]	0,71	1,00	1,60	2,30	3,10	4,80	6,90	9,20	9,20
	$V_{R,k,II}^1$ [kN]	1,14	2,80	3,00	3,30	3,50	4,00	4,11	4,22	4,33

¹ For aluminum with tensile strengths between the specified values, interpolation is allowed.

	<p>Material:</p> <p>Screw: JZ1 stainless steel (A8) - EN ISO 3506 JZ3 stainless steel (A2) - EN ISO 3506 JZ5 stainless steel (A2) - EN ISO 3506</p> <p>Washer: none</p> <p>Component I: Aluminium alloy or steel, thicker than the supporting structure $t_i \geq 5,0$ mm, usually pre-punched from 6,3 mm to 8,5 mm.</p> <p>Component II: S235 to S355 according to EN 10025-1 S280GD to S450GD according to EN 10346 HX350LAD to HX460LAD according to EN 10346 (Table 7.1) Aluminium alloy according to EN 573 (Table 7.2)</p>
---	--

Table 7.1: Single-layer supporting structure made of S280GD to S450GD, HX350LAD to HX460LAD or S235 to S355

$t_{N,II}$ [mm]	1,25	1,50	2,00	3,00	4,00	5,00	6,00	
d_{pd} [mm]	Ø 5,0		Ø 5,3				Ø 5,5	
S280GD	$N_{R,k,II}^1$ [kN]	2,00	2,70	3,60	6,00	8,80	11,60	13,40
	$V_{R,k,II}^1$ [kN]	4,01	4,99	6,06	6,40	6,74	7,08	7,42

¹ S275 to S355, S390GD to S450GD and HX340LAD to HX460LAD only for JZ5-6,3xL.

Table 7.2: Single-layer aluminum alloy supporting structure according to EN 573

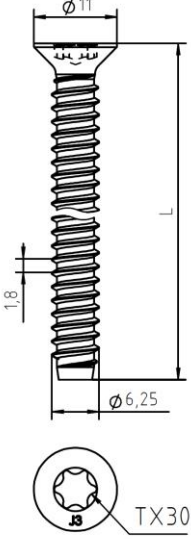
$t_{N,II}$ [mm]	1,20	1,50	2,00	2,50	3,00	4,00	5,00	6,00	7,00	
d_{pd} [mm]	Ø 4,5				Ø 5,0	Ø 5,3		Ø 5,5		
$R_m \geq 165$ N/mm ²	$N_{R,k,II}^1$ [kN]	0,54	0,77	1,23	1,77	2,38	3,68	5,30	7,06	7,06
	$V_{R,k,II}^1$ [kN]	1,52	2,26	3,50	3,99	4,48	5,32	6,15	6,35	6,55
$R_m \geq 215$ N/mm ²	$N_{R,k,II}^1$ [kN]	0,71	1,00	1,60	2,30	3,10	4,80	6,90	9,20	9,20
	$V_{R,k,II}^1$ [kN]	1,95	2,95	4,56	5,20	5,83	6,56	7,28	7,91	8,54

¹ For aluminum with tensile strengths between the specified values, interpolation is allowed.

Characteristic capacities of the fastener	Annex 9
JZ1-S-6,3xL, JZ3-S-6,3xL and JZ5-S-6,3xL	